

# Product Specifications

Receiving card

**HD-R512T**

V1.1 20201208

## 1. Overview

R512T, on-board 12\*HUB75E ports, compatible with R500/R508/R512/  
R512S/R516/R612, etc.

## 2. Parameters

<b>With sending card</b>	Dual-mode sending box, Asynchronous sending card, Synchronous sending card, Video processor of VP series.
<b>Module type</b>	Compatible with all common IC module, supported most PWM IC module.
<b>Scan mode</b>	Supports any scanning method from static to 1/64 scan
<b>Communication method</b>	Gigabit Ethernet
<b>Control range</b>	Recommend: 65,536 pixels (128*512) Outdoor module width $\leq 256$ , Indoor module width $\leq 128$
<b>Multi-card connection</b>	Receiving card can be put in any sequence
<b>Gray scale</b>	256~65536
<b>Smart setting</b>	A few simple steps to complete the smart settings, through the screen layout can be set to go with any alignment of the screen unit board
<b>Test functions</b>	Receiving card integrated screen test function, Test display brightness uniformity and display module flatness.
<b>Communication distance</b>	Super Cat5,Cat6 network cable within 80 meters
<b>Port</b>	5V DC Power*2,1Gbps Ethernet port*2, HUB75E*12
<b>Input voltage</b>	4V-6V
<b>Power</b>	5W

### 3. Connection Method

Connection diagram of connecting R512S with display player box:

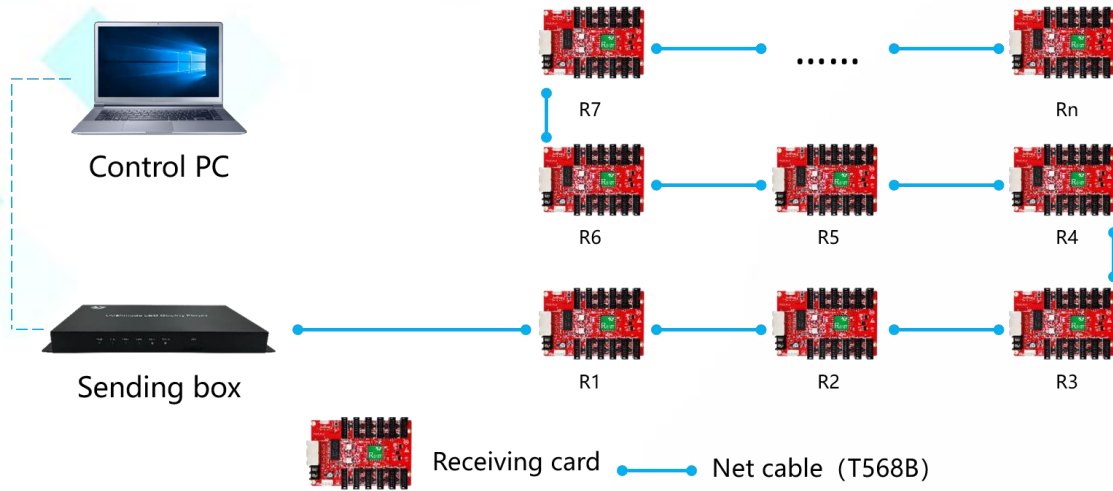

### 4. Dimensions

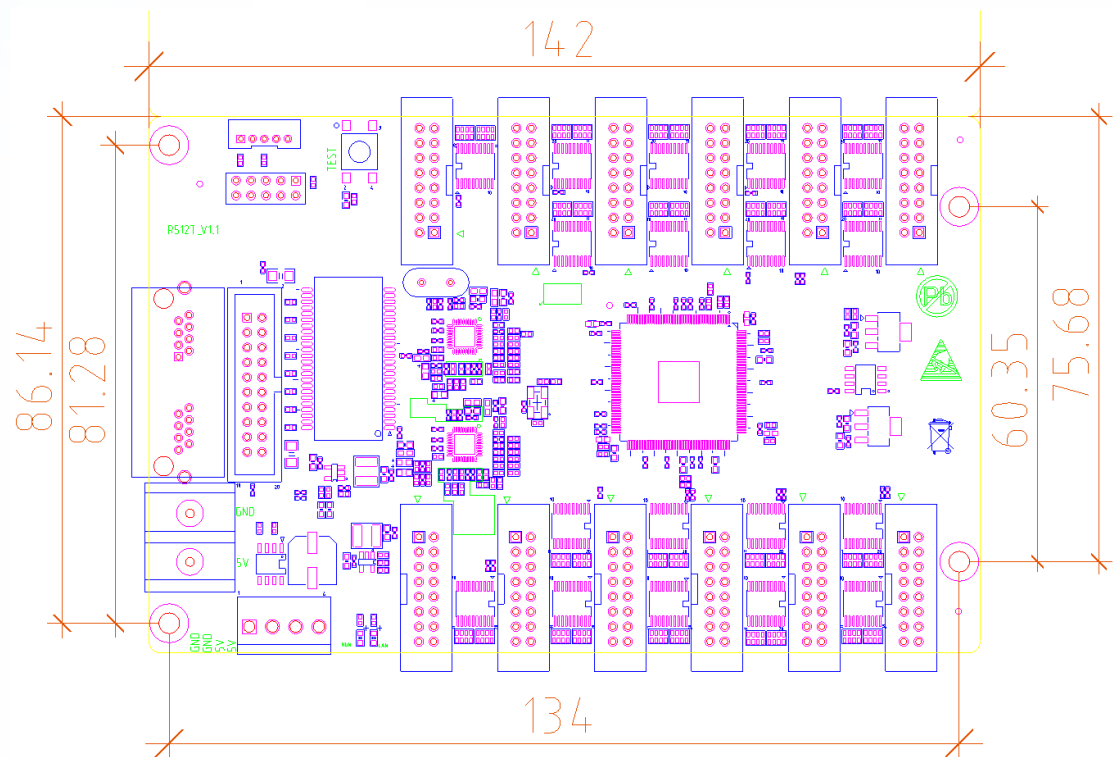

## 5. Interface Definition

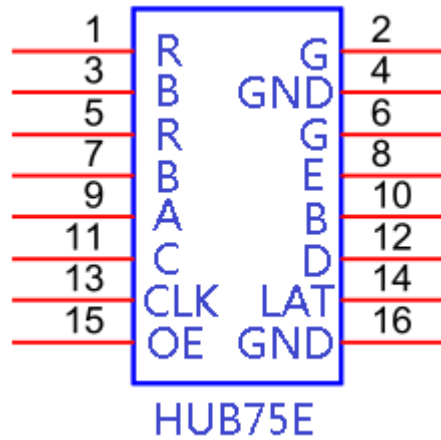

## 6. Appearance Description

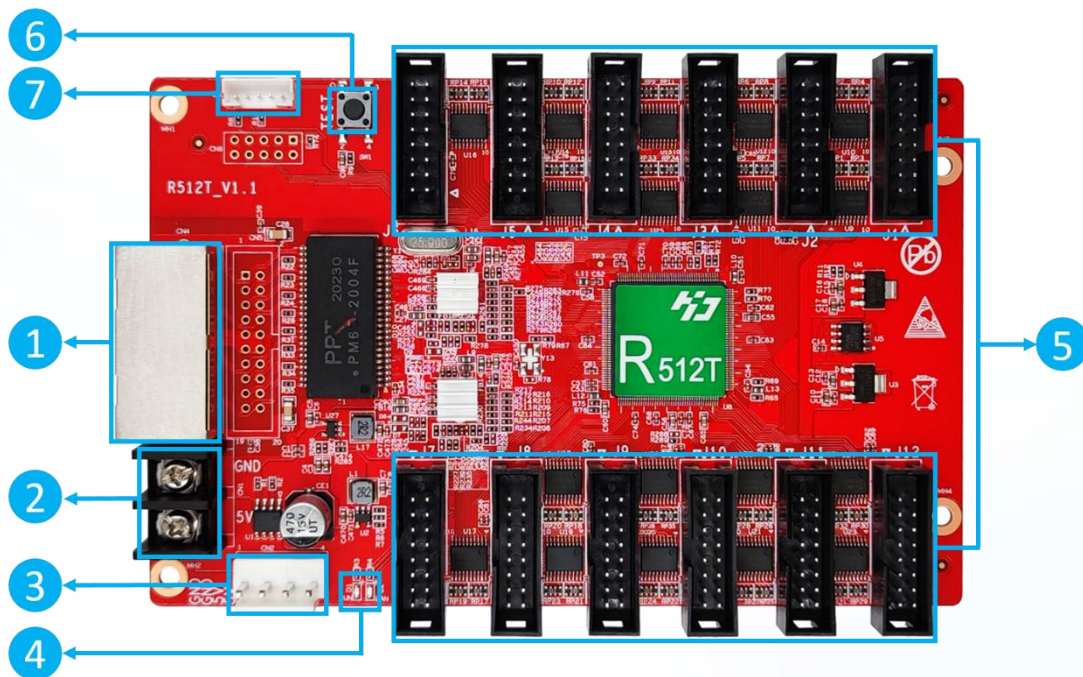

①: Gigabit Ethernet port, used to connect the sending card or receiving card, the same two network ports are interchangeable,

②: Power interface, can be accessed with 4.5V ~ 5.5V DC voltage;



- ③： Power interface, can be accessed with 4.5V ~ 5.5V DC voltage; (②,③ connect one of them is ok.)
- ④： Work indicator, D1 flashes to indicate that the control card is running normally; D2 flashes quickly to indicate that Gigabit has been recognized and data is being received.
- ⑤： HUB75Eport, connect to the modules,
- ⑥： Test button, used to test display brightness uniformity and display module flatness.
- ⑦： External indicator light, run light and data light.

## 7. Technical Parameters

	Minimum	Typical	Maximum
<b>Rated voltage(V)</b>	4.2	5.0	5.5
<b>Storage temperature(°C)</b>	-40	25	105
<b>Work environment temperature(°C)</b>	-40	25	80
<b>Work environment humidity (%)</b>	0.0	30	95
<b>Net weight (kg)</b>	0.091		
<b>Certificate</b>	CE, FCC, RoHS		

## Precautions

- 1) ensure the system long-term stable running, please keep to use the standard 5V power supply voltage.
- 2) Different production batches, color appearance and labels may be different.